

## Hinge– Surface Mount 5”

**HINGE**

### JCP Models Description

J-7-9101	5” Full Surface Weld On Hinge x USP
J-7-9102	5” Full Surface Bolt On Hinge x USP
J-7-9105	5” Half Surface Weld On Hinge x USP
J-7-9106	5” Half Surface Bolt On Hinge x USP
J-7-9109	5” Gap Weld On Hinge x USP
J-7-9110	5” Gap Bolt On Hinge x USP

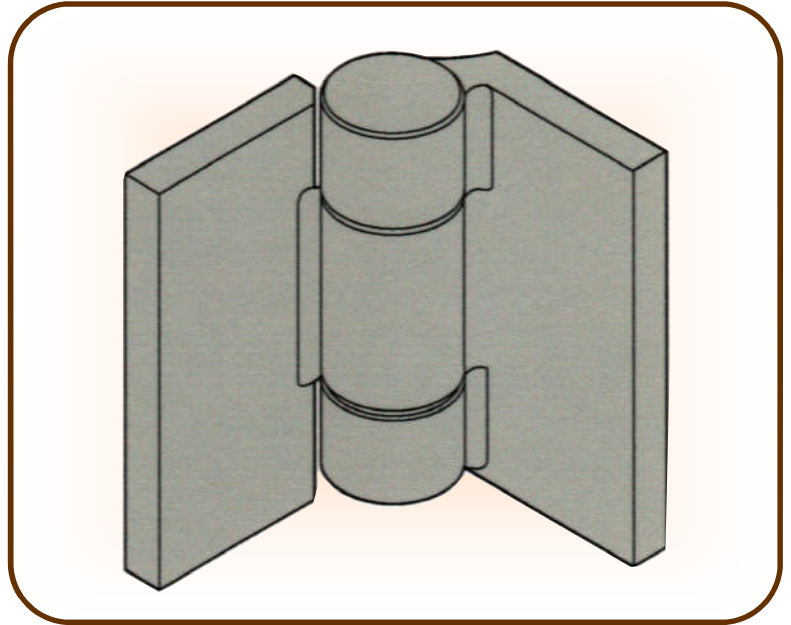

**JCP Specifications:** The JCP surface mount hinge is 5” high x 6” across the leafs and 1/2” thick cold rolled steel with a USP finish. The hinge has a hardened alloy steel pin that is concealed and non-removable, and a heavy-duty thrust and radial bearings. The hinge can be supplied as a weld on unit or can be provided with mounting holes, mounting bolts are not included and must be supplied by others. Short leaves are available as an special order product, please contact your sales representative for special ordering instructions.

Always verify that you have the correct template for your specific project.



**JAILS CORRECTIONAL PRODUCTS** A Division of **FABCOR, Inc.**

350 South Ohio Street, P.O. Box 58  
Minster, Ohio 45865  
www.fabcor.com

Phone: (419) 628-4428  
Fax: (419) 628-2899  
E-mail: jails@fabcor.com

Hardware Assembly

**HA-04.02**

Revision C

©2003 Fabcor, Inc.